

TTK 105 S / TTK 105 S HC

EN

INSTRUCTIONS
DEHUMIDIFIER



 TROTEC

Table of contents

Information on the use of this instructions 2

Safety 2

Information about the device..... 5

Transport and storage..... 6

Assembly and start-up..... 7

Operation 8

Errors and faults..... 10

Maintenance 12

Technical annex..... 15

Disposal 19

Information on the use of this instructions

Symbols



Danger

This symbol indicates dangers to the life and health of persons due to extremely flammable gas.



Warning of electrical voltage

This symbol indicates dangers to the life and health of persons due to electrical voltage.



Warning

This signal word indicates a hazard with an average risk level which, if not avoided, can result in serious injury or death.



Caution

This signal word indicates a hazard with a low risk level which, if not avoided, can result in minor or moderate injury.

Note

This signal word indicates important information (e.g. material damage), but does not indicate hazards.



Info

Information marked with this symbol helps you to carry out your tasks quickly and safely.



Follow the manual

Information marked with this symbol indicates that the instructions must be observed.

You can download the current version of the instructions and the EU declaration of conformity via the following link:



TTK 105 S
TTK 105 S HC



<https://hub.trotec.com/?id=41546>

Safety

Read this manual carefully before starting or using the device. Always store the manual in the immediate vicinity of the device or its site of use.



Warning

Read all safety warnings and all instructions.

Failure to follow the warnings and instructions may result in electric shock, fire and/or serious injury.

Save all warnings and instructions for future reference.

This appliance can be used by children aged from 8 years and above and persons with reduced physical, sensory or mental capabilities or lack of experience and knowledge if they have been given supervision or instruction concerning use of the appliance in a safe way and understand the hazards involved.

Children shall not play with the appliance. Cleaning and user maintenance shall not be made by children without supervision.

- Do not use the device in potentially explosive rooms or areas and do not install it there.
- Do not use the device in aggressive atmosphere.
- Only put up the device in an upright, stable position on firm ground.
- Let the device dry out after a wet clean. Do not operate it when wet.
- Do not use the device with wet or damp hands.
- Do not expose the device to directly squirting water.
- Do not cover the device during operation.
- Do not sit on the device.
- This appliance is not a toy. Keep away from children and animals.
- Occasionally observe the device during operation.
- Check accessories and connection parts for possible damage prior to every use of the device. Do not use any defective devices or device parts.

- Ensure that all electric cables outside of the device are protected from damage (e.g. caused by animals). Never use the device if electric cables or the power connection are damaged!
- The mains connection must correspond to the specifications in the Technical annex.
- Insert the mains plug into a properly fused mains socket.
- Observe the device's power input, cable length and intended use when selecting extensions to the power cable. Completely unroll extension cables. Avoid electrical overload.
- Do not under any circumstances use the device if you detect damages on the mains plug or power cable. If the power cable is damaged, it must be replaced by the manufacturer, its service agent or similarly qualified persons in order to avoid a hazard. Defective power cables pose a serious health risk!
- Before carrying out maintenance, care or repair work on the device, remove the mains plug from the mains socket. Hold onto the mains plug while doing so.
- Switch the device off and disconnect the power cable from the mains socket when the device is not in use.
- When positioning the device, observe the minimum distances from walls and other objects as well as the storage and operating conditions specified in the Technical annex.
- Make sure that the air inlet and outlet are not obstructed.
- Make sure that the suction side is kept free of dirt and loose objects.
- Never insert any objects or limbs into the device.
- Do not remove any safety signs, stickers or labels from the device. Keep all safety signs, stickers and labels in legible condition.
- Only transport the device in an upright position with an emptied condensation tank or drain hose.
- Discharge the collected condensate before transport and storage. Do not drink it. Health hazard!
- Only use original spare parts, for otherwise safe and functional operation cannot be ensured.



Safety warnings for devices containing flammable refrigerants

- Only position the device in rooms where potentially leaking refrigerant cannot accumulate. Unventilated rooms, in which the device is installed, operated or stored, must be built in a way to ensure that potentially leaking refrigerant cannot accumulate. This serves to avoid fire or explosion hazards resulting from an ignition of the refrigerant by an electric furnace, cooking stove or another ignition source.
- Only position the device in rooms where there is no source of ignition (e.g. open flames, an active gas appliance or an electric heater).
- Please note that the refrigerant is odourless.
- Only install the device in compliance with the national installation regulations.
- Please observe the local regulations.
- Observe the national gas regulations.
- Only install, operate and store the device in a room measuring more than 4 m².
- Store the device in a way that no mechanical damage can occur.
- Please note that the connected pipelines must not contain any sources of ignition.
- R290 is a refrigerant that complies with European environmental regulations. No part of the cooling circuit may be perforated.
- Observe the maximum refrigerant capacity in the technical data.
- Do not drill through or burn.
- Do not use any means other than those recommended by the manufacturer for accelerating the defrosting process.
- Every person working with or at the refrigerant circuit must be able to provide a certificate of qualification issued by a body accredited by the industry, demonstrating their competence in the safe use of refrigerants based on a procedure well-known in the industry.
- Service work may only be carried out in accordance with the manufacturer's specifications. If maintenance and repair work require the support of additional persons, the person trained in handling flammable refrigerants shall continuously supervise the work carried out.
- The entire refrigerant circuit is a maintenance-free, hermetically sealed system and may only be maintained or repaired by specialist companies for cooling and air-conditioning or by Trotec.

Intended use

Only use the device for drying and dehumidifying room air, while adhering to and following the technical data.

In addition, the device may also be used as a kind of clothes dryer to dry wet laundry.

Intended use comprises:

- dehumidifying and drying:
 - living rooms, bedrooms and basements
 - bathrooms
 - holiday homes, caravans
- maintaining the dryness of:
 - storage spaces, archives, laboratories, garages
 - changing rooms etc.

Any use other than the intended use is regarded as misuse.

Reasonably foreseeable misuse

- The device is not intended for industrial use.
- Do not place any objects, e.g. clothing, on the device.
- Do not use the device out of doors.
- Never immerse the device in water.
- Do not make any unauthorised modifications, alterations or structural changes to the device.
- Do not place the device on wet or flooded ground, e.g. near floor drains.

Personnel qualifications

People who use this device must:

- be aware of the dangers that occur when working with electric devices in damp areas.
- have read and understood the instructions, especially the Safety chapter.

Maintenance tasks which require the housing to be opened must only be carried out by specialist companies for cooling and air-conditioning or by Trotec.

Safety signs and labels on the device

Note

Do not remove any safety signs, stickers or labels from the device. Keep all safety signs, stickers and labels in legible condition.

The following safety signs and labels are attached to the device:

TTK 105 S / TTK 105 S HC

WARNING • WARNUNG • ATTENTION

DE Das Gerät muss in einem Raum mit einer Grundfläche größer als 4 m² aufgestellt, betrieben und gelagert werden.

EN Appliance shall be installed, operated and stored in a room with floor area larger than 4 m².

FR L'appareil doit être installé, utilisé et entreposé dans une pièce avec une surface supérieure à 4 m².



Follow the manual

This symbol indicates that the instructions must be observed.



Follow the repair manual

Disposal, maintenance and repair work of the refrigerant circuit may only be carried out in accordance with the manufacturer's specifications and by persons having a certificate of qualification.

A corresponding repair manual is available from the manufacturer upon request.

Residual risks



Danger

Natural refrigerant propane (R290)!

H220 – Extremely flammable gas.

H280 – Contains gas under pressure; may explode if heated.

P210 – Keep away from heat, sparks, open flames and other ignition sources. No smoking.

P377 – Leaking gas fire: Do not extinguish, unless leak can be stopped safely.

P410+P403 – Protect from sunlight. Store in a well-ventilated place.



Warning of electrical voltage

Work on the electrical components must only be carried out by an authorised specialist company!



Warning of electrical voltage

Risk of electric shock!

The device is not protected against water.

There is a risk of electric shock!

Never use the device in areas where dripping, spraying or running water can enter the device! Never immerse the device in water!



Warning of electrical voltage

Before any work on the device, remove the mains plug from the mains socket!

Do not touch the mains plug with wet or damp hands.

Hold onto the mains plug while pulling the power cable out of the mains socket.



Warning

Dangers can occur at the device when it is used by untrained people in an unprofessional or improper way! Observe the personnel qualifications!



Warning

The device is not a toy and does not belong in the hands of children.



Warning

Risk of suffocation!

Do not leave the packaging lying around. Children may use it as a dangerous toy.

Note

Do not operate the device without an air filter inserted into the air inlet!

Without the air filter, the inside of the device will be heavily contaminated. This could reduce the performance and result in damage to the device.

Behaviour in the event of an emergency

1. Switch the device off.
2. Disconnect the device from the mains feed-in: Hold onto the mains plug while pulling the power cable out of the mains socket.
3. Do not reconnect a defective device to the mains.

Information about the device

Device description

The device uses the principle of condensation to automatically dehumidify rooms.

The fan sucks damp room air through the air inlet, the air filter, the evaporator and to the condenser located behind it. The air is cooled at the cold evaporator until it is below the dew point. Water vapour contained in the room air precipitates on the evaporator fins as condensation or rime. The dehumidified, cooled air is slightly warmed at the condenser and blown out again. The drier air thus conditioned mixes with the air in the room. The humidity in the room where the device is positioned is reduced as air constantly circulates through the device.

Depending on the air temperature and the relative humidity, the condensed water either drops continuously or only during the defrost phase through the integrated drain nozzle into the condensation tank below. It is fitted with a float to measure the filling level.

The device has a control panel for operating and controlling the functions.

Once the maximum filling level of the condensation tank is reached or in case the condensation tank is not installed correctly, the condensation tank indicator light (see chapter Operation) on the control panel is illuminated. The device switches off. The condensation tank indicator light only goes out again once the emptied condensation tank is reinserted.

Optionally, the condensed water can be drained by attaching a hose at the condensation connection.

The device can reduce the relative humidity of a room to approx. 30 %.

In addition, the device may also be used as a kind of clothes dryer to dry wet laundry in living or working spaces.

Because of the heat radiation generated during operation, the room temperature may rise slightly.

The device TTK 105 S HC is further provided with an operating hours counter.

Device depiction

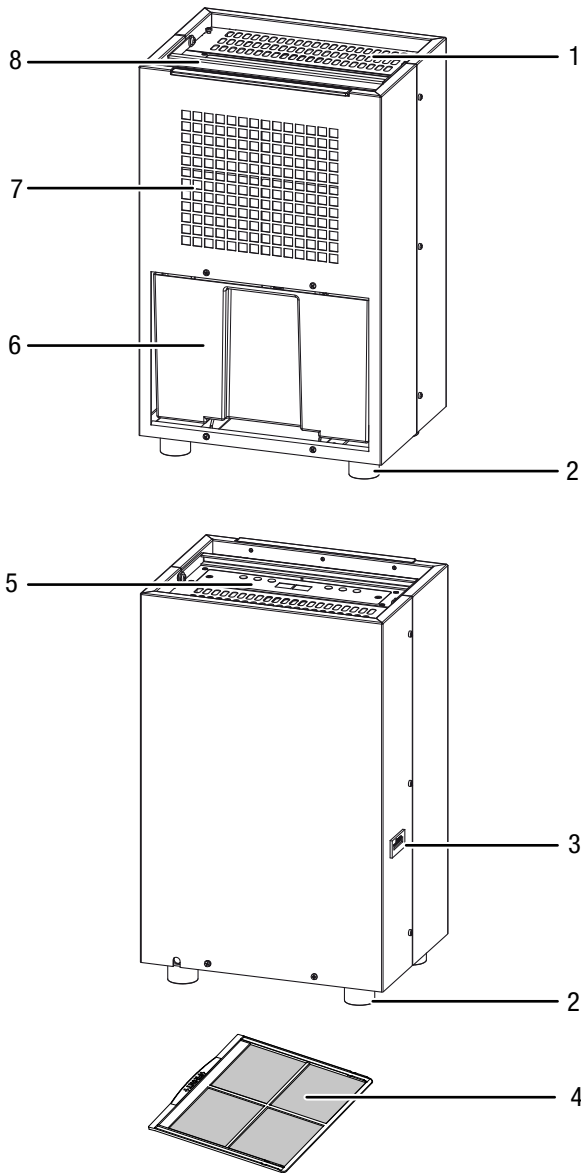

No.	Designation
1	Air outlet
2	Feet
3	Operating hours counter (TTK 105 S HC)
4	Air filter
5	Control panel
6	Condensation tank
7	Air inlet with air filter
8	Transport handle

Transport and storage

Note

If you store or transport the device improperly, the device may be damaged.
 Note the information regarding transport and storage of the device.

Transport

Please note that additional transport regulations might apply to devices containing flammable refrigerants. The equipment's arrangement and the maximum number of components to be transported together can be gathered from the applicable transport regulations.

To make the device easier to transport, it is fitted with a carry handle.

Before transporting the device, observe the following:

- Switch the device off.
- Hold onto the mains plug while pulling the power cable out of the mains socket.
- Drain the remaining condensate from the device and the condensation drain hose (see chapter Maintenance).
- Do not use the power cable to drag the device.

After transporting the device, proceed as follows:

- Set up the device in an upright position after transport.

Storage

Before storing the device, proceed as follows:

- Drain the remaining condensate from the device and the condensation drain hose (see chapter Maintenance).
- Hold onto the mains plug while pulling the power cable out of the mains socket.
- Drain any possibly remaining condensate.

When the device is not being used, observe the following storage conditions:

- Only store the device in a room measuring more than 4 m².
- Only position the device in rooms where there is no source of ignition (e.g. open flames, an active gas appliance or an electric heater).
- Store the device in a dry location and protected from frost and heat.
- Store the device in an upright position where it is protected from dust and direct sunlight.
- If required, use a cover to protect the device from invasive dust.
- Place no further devices or objects on top of the device to prevent it from being damaged.

Assembly and start-up

Scope of delivery

- 1 x Device
- 1 x Air filter
- 1 x Condensation drain hose
- 1 x Hose barb
- 1 x Metal cover for sensor
- 2 x Screw
- 1 x Manual

Unpacking the device

1. Open the cardboard box and take the device out.
2. Completely remove the packaging.
3. Fully unwind the power cable. Make sure that the power cable is not damaged and that you do not damage it during unwinding.

Start-up

When positioning the device, observe the minimum distance from walls or other objects as described in the chapter Technical annex.

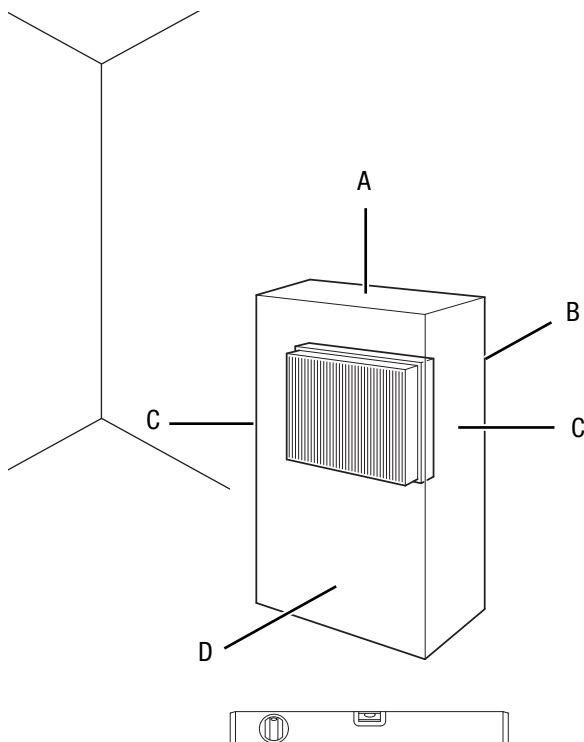

- Only position the device in rooms where there is no source of ignition (e.g. open flames, an active gas appliance or an electric heater).
- Only put up the device in an upright, stable position on firm ground.
- Do not create tripping hazards when laying the power cable or other electric cables, especially when positioning the device in the middle of the room. Use cable bridges.
- Make sure that extension cables are completely unrolled.
- When positioning the device, keep a sufficient distance to heat sources.
- Make sure that no curtains or other objects interfere with the air flow.

Inserting the air filter

Note

Do not operate the device without an air filter inserted into the air inlet!

Without the air filter, the inside of the device will be heavily contaminated. This could reduce the performance and result in damage to the device.

- Make sure that the air filter is installed before switching the device on.

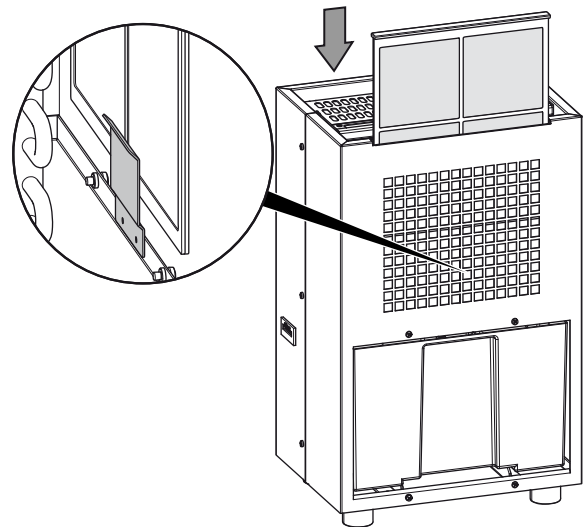

Inserting the condensation tank

- Ensure that the float inside the condensation tank is inserted correctly.
- Ensure that the condensation tank is empty and inserted correctly.

Connecting the power cable

- Insert the mains plug into a properly secured mains socket.

- Before restarting the device, check the condition of the power cable. If there are doubts as to the sound condition, contact the customer service.
- Only position the device in rooms where potentially leaking refrigerant cannot accumulate.

Operation

Notes:

- Avoid open doors and windows.
- After being switched on, the device operates fully automatically.
- The fan permanently runs in dehumidification mode even after the set nominal value has been reached until the device is switched off.

Operating elements

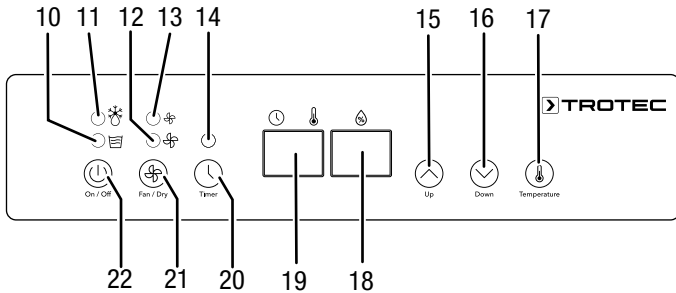

No.	Designation	Meaning
10	Condensation tank full LED	Illuminated when the condensation tank is full or not installed correctly
11	Automatic defrosting LED	Illuminated when automatic defrosting is in progress
12	High fan speed LED	Illuminated when a high fan speed is set
13	Low fan speed LED	Illuminated when a low fan speed is set
14	Timer LED	Illuminated when the timer is programmed
15	Arrow button Up	For setting the relative humidity level (30 to 90 % RH in increments of 5 %)
16	Arrow button Down	
17	Temperature button	Setting the temperature unit (°C or °F)
18	Humidity level segment display	Indicates the current relative room humidity Indicates the desired relative room humidity during setting
19	Temperature / hours segment display	Indicates the current temperature in °C or in °F Indicates the number of hours during timer programming
20	Timer button	Switches the timer function on or off For setting the number of hours for the timer (1 to 24 h)

No.	Designation	Meaning
21	Fan / Dry button	Setting a low or high fan speed
22	On / Off button	Switching the device on or off



Warning of electrical voltage

Risk of electric shock!
The device is not protected against water.
There is a risk of electric shock!
Never use the device in areas where dripping, spraying or running water can enter the device! Never immerse the device in water!

Switching the device on

Once you have completely installed the device as described in the chapter Assembly and start-up, you can switch it on.

1. Press the *On / Off* button (22).
⇒ The device starts in dehumidification mode.

Setting the operating mode

- Dehumidification

Dehumidification

The device keeps running until reaching the desired relative room humidity. Once the desired relative room humidity is exceeded, the compressor switches back on.
The desired relative room humidity can be set within a setting range from 30 % to 90 % in increments of 5 %.

Setting the desired relative room humidity

Setting is possible in the range between 30 % and 90 % in increments of 5 %.
1. Press the arrow buttons (15, 16) to adjust the relative room humidity.
⇒ The desired relative room humidity will be indicated on the *humidity level* segment display (18).

Setting the fan speed

Using this function you can choose between a low and a high fan speed.
1. Press the *Fan / Dry* button (21) to select either high or low fan speed.
⇒ The LED for high (12) or low (13) fan speed lights up depending on the selected setting.

Setting the timer

For the device to switch on or off automatically after a predefined number of hours (1 to 24 h), you can programme the timer.
The timer can be programmed in increments of 1 hour.

Note

The device must not be left unattended in a freely accessible room with an activated timer.

Automatic switch-on

- ✓ The device is switched off.
- 1. Press the *Timer* button (20) to activate the timer.
 - ⇒ The *Timer* LED (14) is illuminated.
 - ⇒ The number of hours is shown on the segment display (19).
- 2. Press the arrow buttons (15, 16) to set the number of hours.
 - ⇒ The number of hours flashes on the segment display (19).
- 3. Wait for approx. 5 seconds in order to save the setting.
 - ⇒ After the predefined time, the device switches itself on.
 - ⇒ The set operating time will be indicated for a few seconds on the segment display (19). Afterwards, the current temperature is displayed again.

Note regarding automatic switch-on:

- Pressing the *On / Off* button (22) deactivates the automatic switch-on function.

Automatic switch-off

- ✓ The device is switched on.
- 1. Press the *Timer* button (20) to activate the timer.
 - ⇒ The *Timer* LED (14) is illuminated.
 - ⇒ The number of hours is shown on the segment display (19).
- 2. Press the arrow buttons (15, 16) to set the number of hours.
 - ⇒ The number of hours flashes on the segment display (19).
- ⇒ After the predefined time, the device switches itself off.
- ⇒ The set operating time will be indicated for a few seconds on the segment display (19). Afterwards, the current temperature is displayed again.

Note regarding automatic switch-off:

- Pressing the *On / Off* button (22) deactivates the automatic switch-off function.

Operation with hose attached to the condensation connection

For continuous operation or unattended dehumidification, please connect the supplied condensation drain hose to the device.

- ✓ A suitable hose (diameter: 1/2 inch) is ready for use.
- ✓ The device is switched off.

1. Remove the condensation tank.

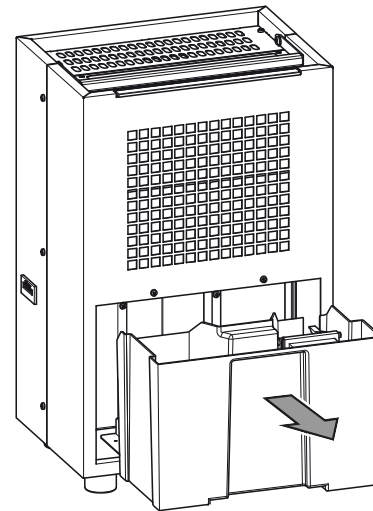

2. Screw down the metal cover next to the sensor for the condensation tank.

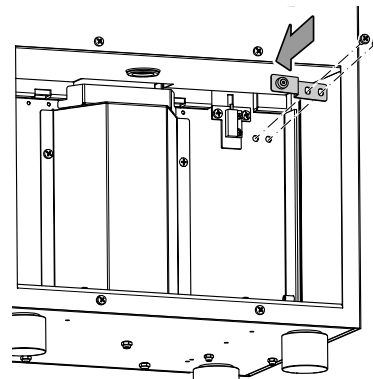

3. Insert the hose barb (23) into the hole of the condensation tray (24).
4. Push one end of the 1/2" hose onto the hose barb (23).

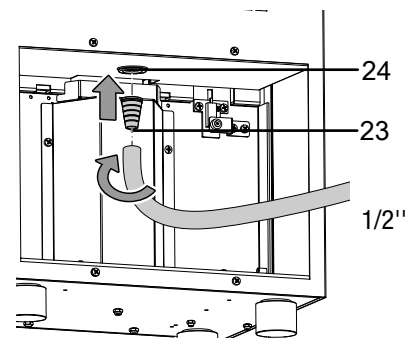

5. Guide the other hose end to a suitable drain or sufficiently dimensioned collection container. Please note that the hose must not be kinked.

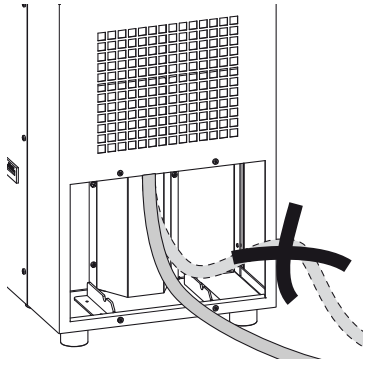

Remove the hose if you want to collect the condensate in the condensation tank again. Allow the hose to dry prior to storage. The hose can be connected in any operating mode for continuous operation.

Automatic defrosting

At low ambient temperatures (below 12 °C), ice may form at the evaporator during dehumidification. The device will then perform automatic defrosting. Dehumidification is briefly interrupted during defrosting. The fan keeps running.

The *automatic defrosting* LED (11) is illuminated throughout the defrosting process.

The duration of defrosting can vary. Do not switch off the device during automatic defrosting. Do not remove the mains plug from the mains socket.

Drying laundry

In addition, the device may also be used as a kind of clothes dryer to dry wet laundry in living or working spaces.

When positioning the device or a clothes horse, please observe the minimum distances specified in the technical data.

The following humidity values are suitable for drying laundry:

- cupboard dry = 46 % relative humidity
- iron dry = 58 % relative humidity
- slightly dried = 65 % relative humidity

Adjust the settings for the relative humidity level to the device (e.g. 60 % relative humidity for iron dry laundry). If necessary, use a measuring device to determine the humidity level.

Shutdown



Warning of electrical voltage

Do not touch the mains plug with wet or damp hands.

- Switch off the device.
- Hold onto the mains plug while pulling the power cable out of the mains socket.
- If necessary, remove the condensation drain hose and any residual fluid from it.
- Empty the condensation tank, if need be.
- Clean the device according to the Maintenance chapter.
- Store the device according to the Transport and storage chapter.

Errors and faults

The device has been checked for proper functioning several times during production. If malfunctions occur nonetheless, check the device according to the following list.

Note

Wait for at least 3 minutes after maintenance and repair work. Only then switch the device back on.

The device does not start:

- Check the power connection.
- Check the power cable and mains plug for damage.
- Check the on-site fusing.
- Check the filling level of the condensation tank and empty it if necessary. The *condensation tank full* LED (10) must not light up.
- Check the condensation tank for correct seating.
- Check the room temperature. Observe the device's permissible operating range according to the technical data. Possibly, the device does not start because the ambient temperature is too low (< 5 °C).

The device is running, but there is no formation of condensate:

- Check the float in the condensation tank for dirt. If necessary, clean the condensation tank. The float must be able to move freely.
- Check the room temperature. Observe the device's permissible operating range according to the technical data. Possibly, the device does not start because the ambient temperature is too low (< 5 °C).
- Ensure that the relative room humidity complies with the technical data.
- Check the preselected relative room humidity. The humidity in the room must be above the selected range.
- Check the air filter for dirt. If necessary, clean or replace the air filter.

- From the outside, check the condenser for dirt (see chapter Maintenance). If the condenser is dirty, have it cleaned by a specialist company or by Trotec.
- The device might carry out an automatic defrost. During automatic defrost, the device does not dehumidify.

The device is loud or vibrates:

- Check whether the device is set up in a stable and upright position.

Condensate is leaking:

- Check the device for leaks.

The compressor does not start:

- Check the room temperature. Observe the device's permissible operating range according to the technical data. Possibly, the device does not start because the ambient temperature is too low (< 5 °C).
- Ensure that the relative room humidity complies with the technical data.
- Check the preselected relative room humidity. The humidity in the room must be above the selected range.
- Check whether the overheating protection of the compressor has tripped. Disconnect the device from the mains and let it cool down for approx. 10 minutes before reconnecting it.
- The device might carry out an automatic defrost. During automatic defrost, the device does not dehumidify.

The device gets very warm, is loud or is losing performance:

- Check the air inlets and air filters for dirt. Remove external dirt.
- From the outside, check the device for dirt (see chapter Maintenance). If the inside of the device is dirty, have it cleaned by a specialist company for cooling and air-conditioning or by Trotec.

The device still does not operate correctly after these checks:

Please contact the customer service. If necessary, bring the device to a specialist company for cooling and air-conditioning or to Trotec for repair.

Error codes

The following error messages can be displayed on the segment display:

Error code	Cause	Remedy
30	Humidity sensor – circuit interrupted The humidity level is lower than 30 % RH.	Switch the device off and contact the customer service.
90	Humidity sensor – short circuit The humidity level is higher than 90 % RH.	Switch the device off and contact the customer service.
Lo	The current room temperature is lower than 0 °C. Temperature sensor – circuit interrupted	Activate the dehumidifier at room temperatures which comply with the technical data. Should the alarm persist, please contact the customer service.
Hi	The current room temperature is higher than 50 °C. Temperature sensor – short circuit	Activate the dehumidifier at room temperatures which comply with the technical data. Should the alarm persist, please contact the customer service.
E5	Chip communication failure	Switch the device off and contact the customer service.

Maintenance

Maintenance intervals

Maintenance and care interval	before every start-up	as needed	at least every 2 weeks	at least every 4 weeks	at least every 6 months	at least annually
Check air inlet and outlet for dirt and foreign objects and clean if necessary	X			X		
Clean the exterior		X				X
Visually check the inside of the device for dirt		X				X
Check the air filter for dirt and foreign objects and clean or replace if necessary	X		X			
Replace the air filter					X	
Check for damage	X					
Check the attachment screws		X				X
Test run						X
Empty and clean the condensation tank and/or drain hose		X				

Maintenance and care log

Device type:

Device number:

Maintenance and care interval	1	2	3	4	5	6	7	8	9	10	11	12	13	14	15	16
Check air inlets and outlets for dirt and foreign objects and clean if necessary																
Check the air filter for dirt and foreign objects and clean or replace if necessary																
Clean the exterior																
Visually check the inside of the device for dirt																
Replace the air filter																
Check the attachment screws																
Test run																
Empty and clean the condensation tank and/or drain hose																
Comments																

1. Date: Signature:	2. Date: Signature:	3. Date: Signature:	4. Date: Signature:
5. Date: Signature:	6. Date: Signature:	7. Date: Signature:	8. Date: Signature:
9. Date: Signature:	10. Date: Signature:	11. Date: Signature:	12. Date: Signature:
13. Date: Signature:	14. Date: Signature:	15. Date: Signature:	16. Date: Signature:

Activities required before starting maintenance



Warning of electrical voltage

Do not touch the mains plug with wet or damp hands.

- Switch the device off.
- Hold onto the mains plug while pulling the power cable out of the mains socket.



Warning of electrical voltage

Tasks which require the device to be opened must only be carried out by authorised specialist companies or by Trotec.

Refrigerant circuit



Danger

Natural refrigerant propane (R290)!

H220 – Extremely flammable gas.

H280 – Contains gas under pressure; may explode if heated.

P210 – Keep away from heat, sparks, open flames and other ignition sources. No smoking.

P377 – Leaking gas fire: Do not extinguish, unless leak can be stopped safely.

P410+P403 – Protect from sunlight. Store in a well-ventilated place.

- The entire refrigerant circuit is a maintenance-free, hermetically sealed system and may only be maintained or repaired by specialist companies for cooling and air-conditioning or by Trotec.

Safety signs and labels on the device

Check the safety signs and labels attached to the device at regular intervals. Replace illegible safety signs!

Cleaning the housing

Clean the housing with a soft, damp and lint-free cloth. Make sure that no moisture enters the housing. Protect electrical components from moisture. Do not use any aggressive cleaning agents such as cleaning sprays, solvents, alcohol-based or abrasive cleaners to dampen the cloth.

Visual inspection of the inside of the device for dirt

1. Remove the air filter.
2. Use a torch to illuminate the openings of the device.
3. Check the inside of the device for dirt.
4. If you see a thick layer of dust, have the inside of the device cleaned by a specialist company for cooling and air-conditioning or by Trotec.
5. Put the air filter back in.

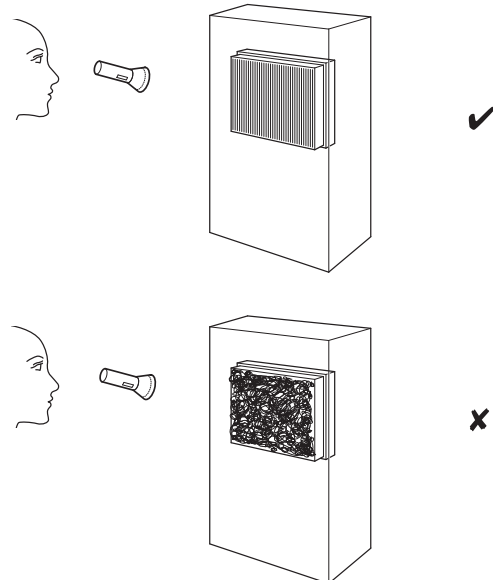

Cleaning the air filter

Note

Ensure that the air filters are neither worn nor damaged. The corners and edges of the air filters must not be deformed or rounded. Before reinserting the air filters, make sure that they are undamaged and dry!

The air filters have to be cleaned as soon as they are dirty. This is brought to light e.g. by a reduced capacity (see chapter Errors and faults).

1. Remove the air filter from the device.

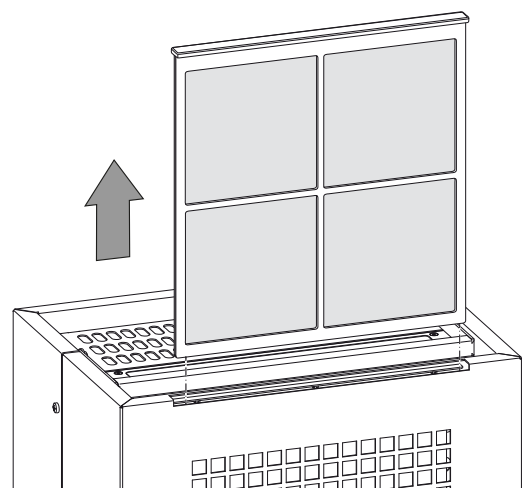

- Clean the filter using a slightly damp, soft, lint-free cloth. If the filter is heavily contaminated, clean it with warm water mixed with a neutral cleaning agent.

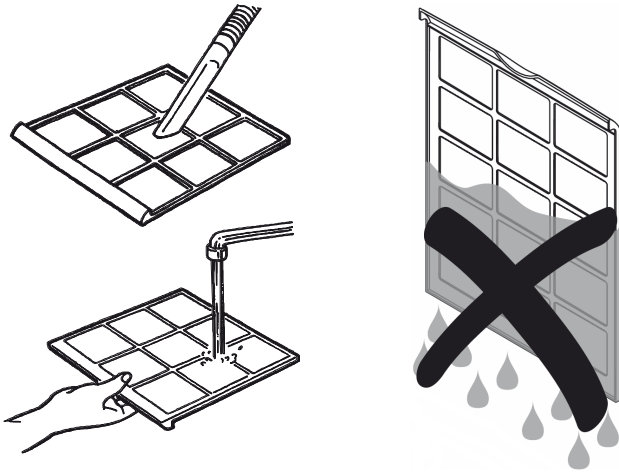

- Allow the filter to dry completely. Do not insert a wet filter into the device!
- Reinsert the air filter into the device.

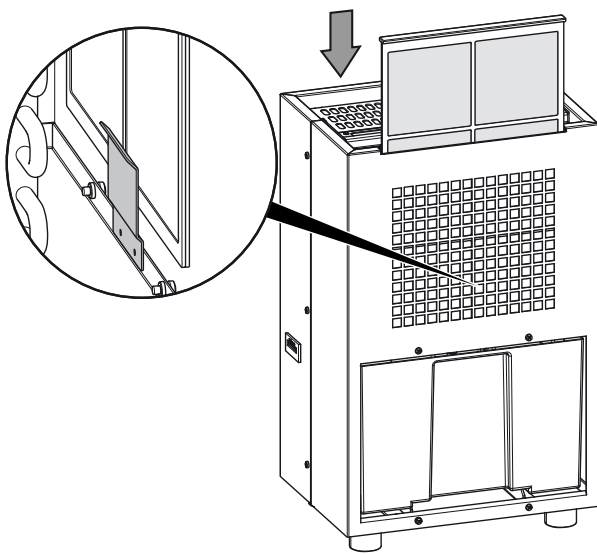

Emptying the condensation tank

If the condensation tank is full or not installed correctly, the condensation tank full LED (10) will be illuminated. The compressor and fan will switch off.

- Take the condensation tank out of the device.

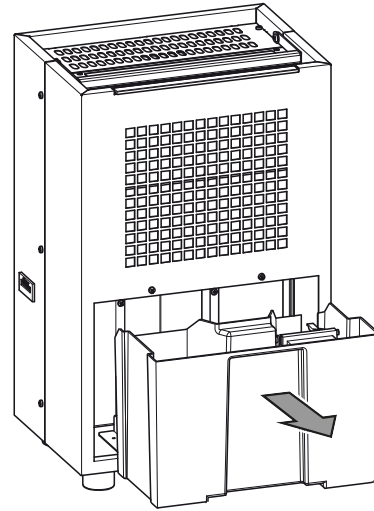

- Empty the condensation tank over a drain or sink.

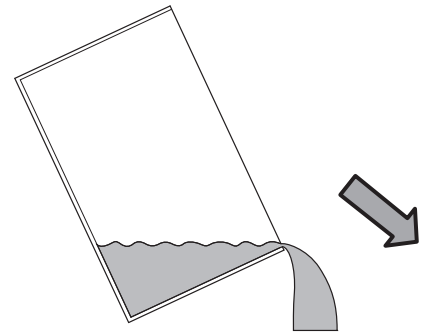

- Rinse the condensation tank with clear water. Regularly clean the condensation tank using a mild cleaning agent (no detergent!).
- Refit the condensation tank into the device. Make sure not to damage the float when inserting or removing the condensation tank. In doing so, make sure that the float is positioned correctly. In doing so, make sure that the condensation tank is inserted correctly, for otherwise the device cannot be switched back on.

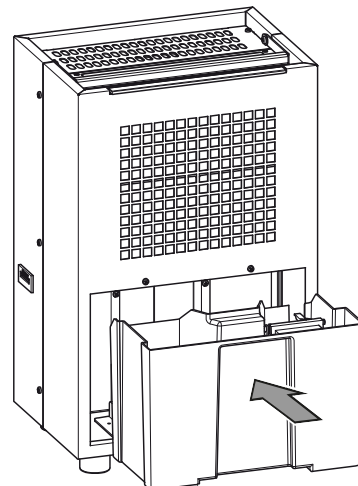

Activities required after maintenance

If you want to continue using the device:

- Reconnect the device to the mains.

If you do not intend to use the device for a considerable time:

- Store the device according to the Transport and storage chapter.

Technical annex

Technical data

Parameter	Value
Model	TTK 105 S / TTK 105 S HC
Dehumidifying capacity max.	30 l / 24 h
Air flow rate	173 m ³ /h
Operating range (temperature)	5 °C – 32 °C
Operating range (relative humidity)	30 % to 90 % RH
Pressure suction side	1.2 MPa
Pressure outlet side	2.4 MPa
Max. permissible pressure	2.6 MPa
Mains connection	220–240 V / 50 Hz
Max. power consumption	0.50 kW
Nominal current	2.1 A
Refrigerant	R290
Amount of refrigerant	125 g
GWP factor	3
CO ₂ equivalent	0.000375 t
Water tank	5.2 l
Sound pressure level	50 dB(A)
Dimensions (length x width x height)	250 x 342 x 517 mm
Minimum distance to walls and other objects	A: top: 50 cm B: rear: 50 cm C: side: 50 cm D: front: 50 cm
Weight	14.5 kg

Wiring diagram TTK 105 S / TTK 105 S HC

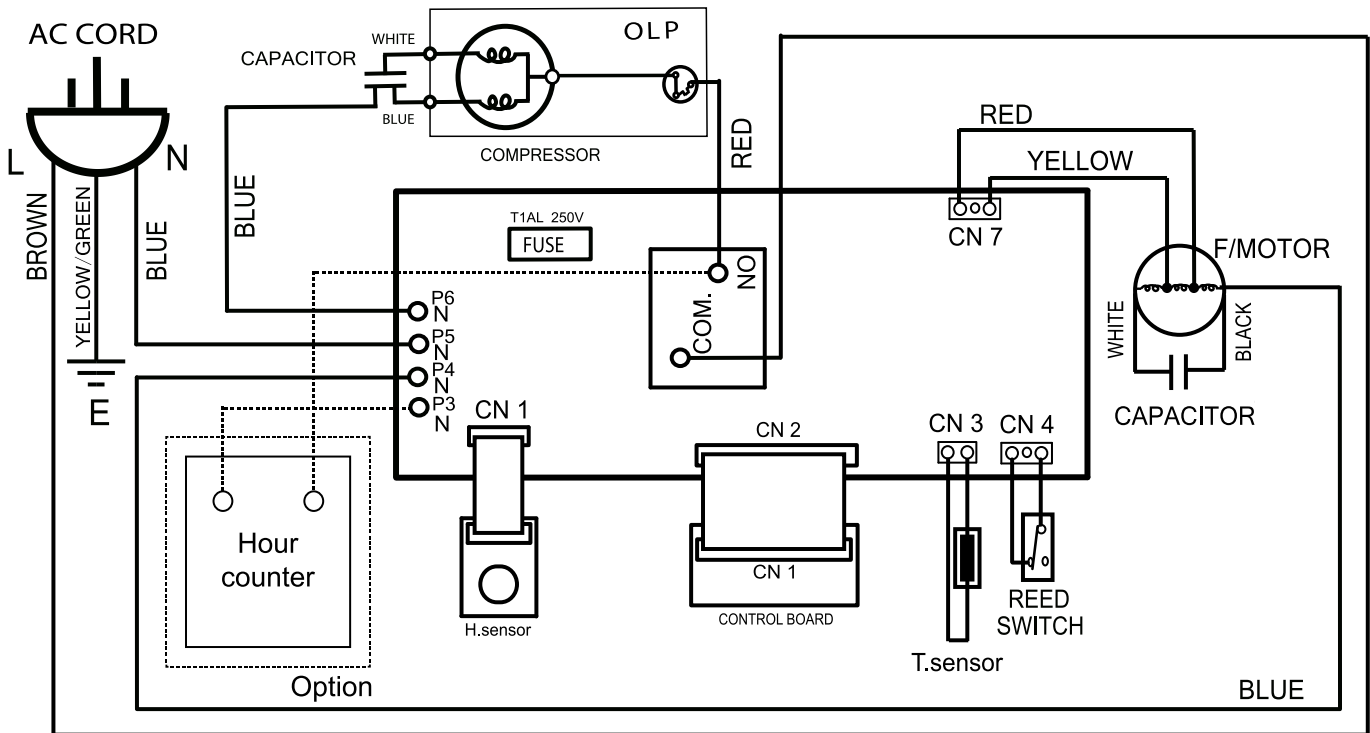

Overview of spare parts TTK 105 S / TTK 105 S HC

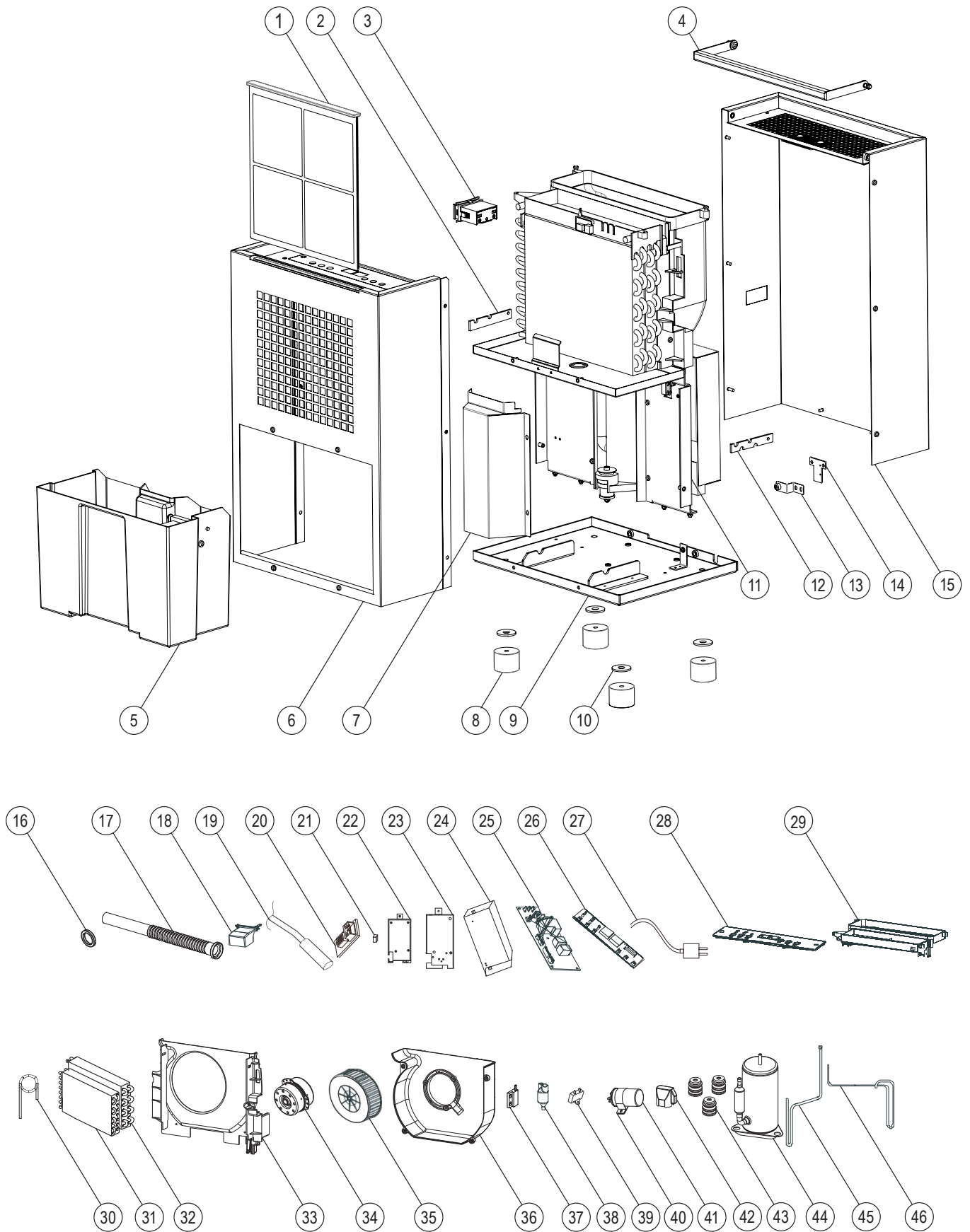

No.	Designation	Article number	No.	Designation	Article number
1	Filter TTK 105 S	P10001469	24	Schutzabdeckung	TTK 105 S - D7710-030
2	Registerhalter einfach	P10007738	25	Steuerplatine	TTK 105 S - D2515-720-02
3	Betriebsstundenzähler (optional)	P10001245	26	Bedienfeld-Platine	TTK 105 S - D2519-360-06
4	Griff	P10001476	27	Netzkabel	TTK 105 S - D3700101000EU
5	Kondensatbehälter	P10001467	28	Bedienfeld	TTK 105 S - D4253-510-H-11
6	Rück Paneele	P10001470	29	Register Fixierung	TTK 105 S - D5812-45D-A-22
7	Abdeckung	P10001474	30	Kappilar	TTK 105 S - A6204-740
8	Gummipuffer	P10000425	31	Wärmetauscher-Kondenser	TTK 105 S - D3422-601
9	Bodenplatte	P10001473	32	Wärmetauscher-Verdampfer	TTK 105 S - D3420-443
10	Unterlegscheibe	P10000211	33	Ventilatorgehäuse 1	TTK 105 S - D5300-29A-A-22
11	Stützgerüst	P10001472	34	Ventilatormotor	TTK 105 S - D7450-060
12	Registerhalter doppelt	P10007737	35	Ventilator Laufrad	TTK 105 S - D5304-110-A-22
13	Halter Magnetkontakt	P10007742	36	Ventilatorgehäuse	TTK 105 S - D5300-310-AF-22
14	Positionsblech Reed Kontakt	P10007741	37	Reedkontakt	TTK 105 S - D2522-760
15	Frontpaneele	P10001471	38	Y - Rohrstück	TTK 105 S - D6210-060
16	Dichtring	TTK 105 S - D3204-060	39	Kondensator (1µF/450V)	TTK 105 S - CA0100451321
17	Schlauch	TTK 105 S - D7216-010	40	Montageschelle Kondensator	TTK 105 S - A5806-100
18	Schwimmer	TTK 105 S - D5405-540-A-A5	41	Kondensator (12µF/450V)	TTK 105 S - CA1200451241
19	Temperaturfühler Register	TTK 105 S - D2522-620-08	42	Kondensator Abdeckung	TTK 105 S - A6101-920-AP-11
20	Feuchtesensor	TTK 105 S - D2522-410	43	Kompressorfüße (Gummi)	TTK 105 S - D5600-142
21	Schwimmermagnet	TTK 105 S - D7431-010	44	Kompressor	TTK 105 S - D3203-890
22	Blech 1 Elektrobox	TTK 105 S - D5812-440-AP-11	45	Saug Leitung	TTK 105 S - D6225-790
23	Blech 2 Elektrobox	TTK 105 S - D7700-030	46	Heißgas Leitung	TTK 105 S - D6230-720

Disposal

Always dispose of packing materials in an environmentally friendly manner and in accordance with the applicable local disposal regulations.



The icon with the crossed-out waste bin on waste electrical or electronic equipment is taken from Directive 2012/19/EU. It states that this device must not be disposed of with the household waste at the end of its life. You will find collection points for free return of waste electrical and electronic equipment in your vicinity. The addresses can be obtained from your municipality or local administration. You can also find out about other return options that apply for many EU countries on the website <https://hub.trotec.com/?id=45090>. Otherwise, please contact an official recycling centre for electronic and electrical equipment authorised for your country.

The separate collection of waste electrical and electronic equipment aims to enable the re-use, recycling and other forms of recovery of waste equipment as well as to prevent negative effects for the environment and human health caused by the disposal of hazardous substances potentially contained in the equipment.

Have the refrigerant (propane) disposed of appropriately and according to the national regulations by a company with the relevant certification (European Waste Catalogue 160504).

Only for United Kingdom

According to Waste Electrical and Electronic Equipment Regulations 2013 (SI 2013/3113) (as amended) devices that are no longer usable must be collected separately and disposed of in an environmentally friendly manner.

Trotec GmbH

Grebener Str. 7
D-52525 Heinsberg

☎ +49 2452 962-400

☎ +49 2452 962-200

✉ info@trotec.com

www.trotec.com